

PART DESCRIPTION	
PART NUMBER	472475
MODEL	47
SHAFT DIAMETER	1.187 ± .0030
BORE DIAMETER	1.874 ± .0010
PART O.D.	1.879 +.0020 / -.0020
WIDTH	.250 ± .0150
MAIN LIP DIA.	N/A
AUX LIP DIA	N/A
LIP MATERIAL	NBR
SPRING MATERIAL	CARBON STEEL
CASE MATERIAL	CARBON STEEL

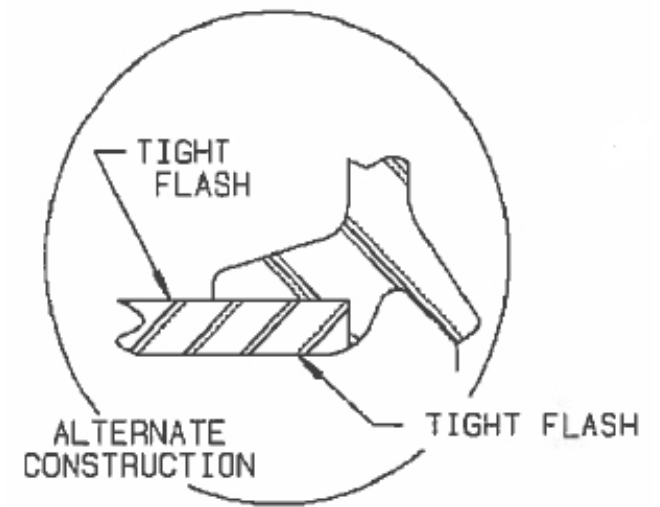

INCH

2017-03-14	SUPERSEDES NONE	472475 TIMKEN INDUSTRIAL SEAL		
INITIAL RELEASE	PROJECTION  ORIGINAL SCALE NOT TO SCALE			
	<b>TIMKEN</b> THE TIMKEN COMPANY CANTON, OHIO, U.S.A.			
A	PRNT = HJ00 10 6A	DRAWN AKJOSHI	CHECKED AKJOSHI	APPROVED DATE 2017-03-14
		THIS DRAWING MUST NOT BE COPIED OR REPRODUCED WITHOUT THE CONSENT OF THE TIMKEN COMPANY		
		BM-60 60 38		

FORMGEN - 3D SOLID MODEL